

DTTM - Drum Tire Testing Machines

A powerful, modular test machine concept

A powerful, modular test machine concept according to valid regulations, customizable to meet your requirements. High precision measurement solutions and hydraulic systems, which were especially developed in-house for tire testing equipment, offer unique test stand solutions with extended life-time. The modularity offers easy extension and modification for changing requirements. Various modules are available for multiple fields of measurement and testing. The high quality standards assure good value for your investment.

- 1-; 2-; 4-Posion test stands
- Various drum diameters available
- Rolling Resistance-Measurement
 - ISO 28580/ 16377/ 9948/ 1816
 - R 117, GB/T 29042-2012
 - SAE J2452/ J1269/ J1270
- Non Uniformity-Measurement
 - ISO 13328/ 23671,
 - SAE J2730/ J332/ J2731
- Force & Moment Measurement
 - SAE J1106/ J1107/ J1987
- High-Speed-/ Endurance-Testing
 - FMVSS 109/ 119/ 139
 - ISO 10231/ 10191
 - SAE J1561/ J1633
 - UN ECE R30/ R54/ R64/ R75/ R106/ R108/ R109
- Wear-Testing
- Cleat-Testing
- Motorcycle-, Passenger-, Light Truck-, Truck and Bus-, OTR-, Aircraft- tire testing
- Solid-tire testing
- Hydraulic-, pneumatic-, electric loading
- Customized layouts, designs, measurements
- Camber and slip variation
- Economic operation with Altracon **Efficient Power Consumption Management – EPCM**
- Altracon **Failure Detection System – FDS** to prevent equipment damages
- Tire dynamic growth measurement
- Remote Service interface



Modular design concept

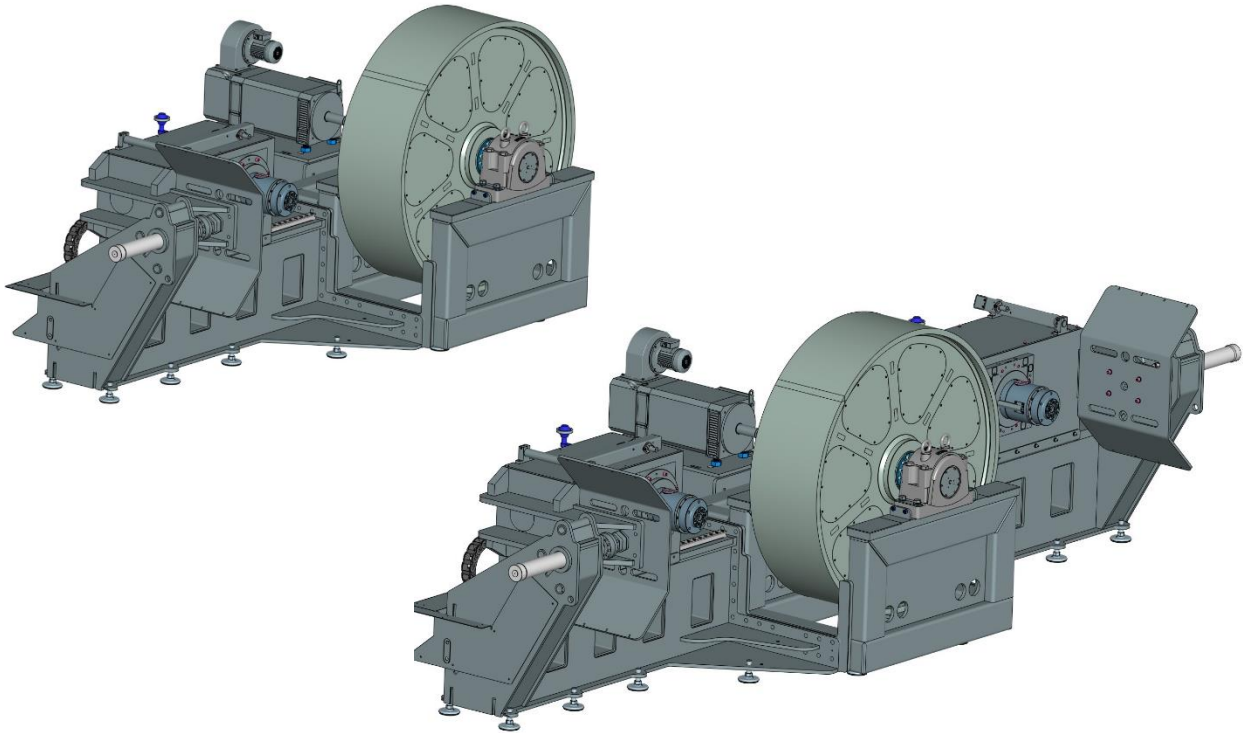

Modular machine concept with standardized interfaces



PCR RR test machine

Contact us to learn more about **Altracon** ● the solution provider